

Thermostatic Valves vs. Electronic Sensing/Solenoid Valves

Thermostatic Valves

Thermostatic valves modulate open or closed in proportion to fluid temperature without the need for an external temperature transducer and external power.

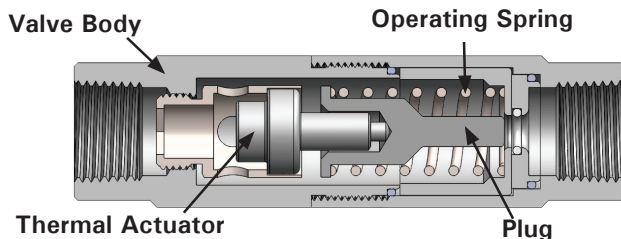

Advantages

- Self-actuating - no external power source is required to operate
- Very high power to size and weight ratio - compact, lightweight designs
- Maintenance free – no periodic calibration
- Highly repeatable position vs. temperature
- Cost - lower product, installation and operation costs than solenoid valves
- Long service life
- Few moving parts
- Excellent for applications in extreme and hazardous environments

Summary

Modulating control of flow provides a balanced temperature within the system, resulting in more efficient operation and reduced stress on the entire system. On/off flow control results in temperature swings which can be reduced by a tighter temperature differential, however this leads to more frequent cycling and decreases longevity of control elements through their excessive use.

The power required to move a typical flow control valve gives an advantage to thermostatic actuators/valves since powerful solenoids are large, heavy, and expensive. Also, since no power connection is needed for thermostatic valves, power failure will not affect valve reliability or cause hazardous conditions.

Thermally actuated valves are highly reliable, repeatable, compact, low cost devices used for many fluid temperature control applications. They are the best temperature solution to a temperature problem.

Electronic Sensing/Solenoid Valves

Solenoid valves require a temperature sensor, amplifier, control electronics, and DC Power to operate.

They use an on/off temperature switch to open or close the valve. The switch's specs determine how accurate it operates and the differential between open and closed.

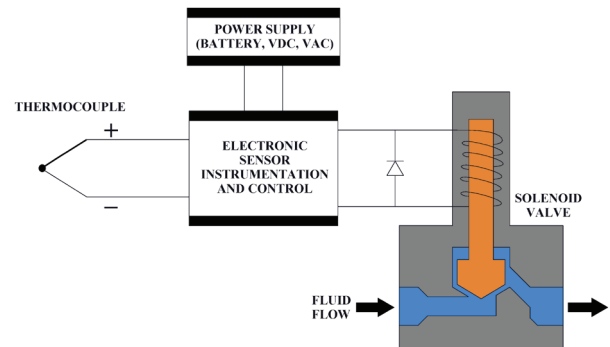

Advantages

- Response time - unlike thermostatic valves that have high thermal inertia, solenoid valves respond very quickly, in milliseconds.
- Accuracy - when properly calibrated, temperature control systems using electronic sensing and solenoid valves can achieve accuracies at better than 0.5°F.